

smartLink HW-PN

PROFINET Access Point for Asset Management

- Access to PROFINET networks independent from the controller
- Integration without interference with the operation of existing installations
- Connect to PROFINET and PROFIBUS devices
- Compatible with products of leading device manufacturers

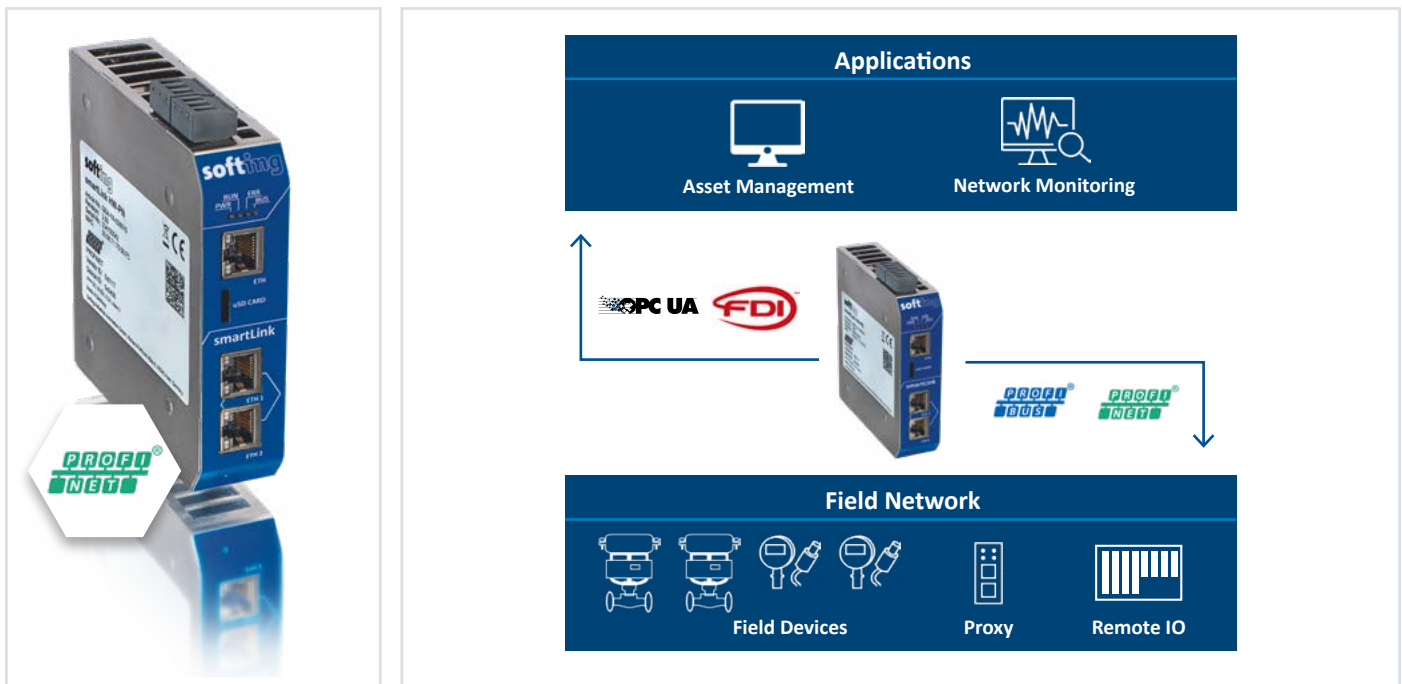

Parameterization, Plant Asset Management and Process Data Provision using Standard Industry Tools

- Independent of configuration tools
- Centralized and time-saving parameterization of PROFINET and PROFIBUS field devices directly from the control room
- Access from Plant Asset Management applications for field devices configuration

Ethernet Access Point to PROFINET networks

- Provides 2nd channel to access the field devices
- Acts as a PROFINET supervisor
- Is part of one PROFINET network
- Integrated 2-port switch for use in line or ring network topologies

Key Component for Transition to State-of-the-Art Technology

- Re-use of existing PROFINET networks without requiring modification
- Access to acyclic data via FDI communication server (OPC UA)

Asset Management and Parameterization of PROFINET Devices

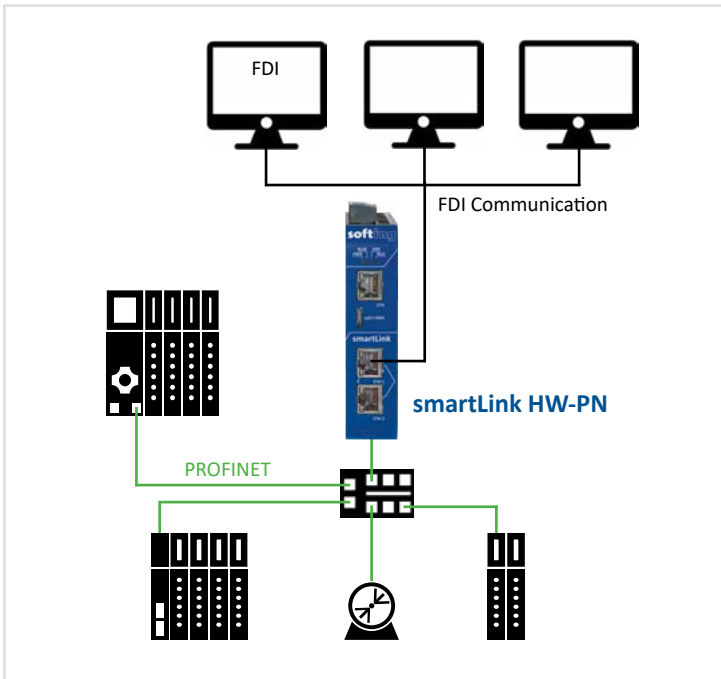

Configuration, Parameterization, Plant Asset Management

- Secure, standardized access to devices
- Parallel to and independent of the controller

Compatible with established communication standards

- Implements the standard FDI communication server interface based on OPC UA

Asset Management and Parameterization of PROFIBUS Devices

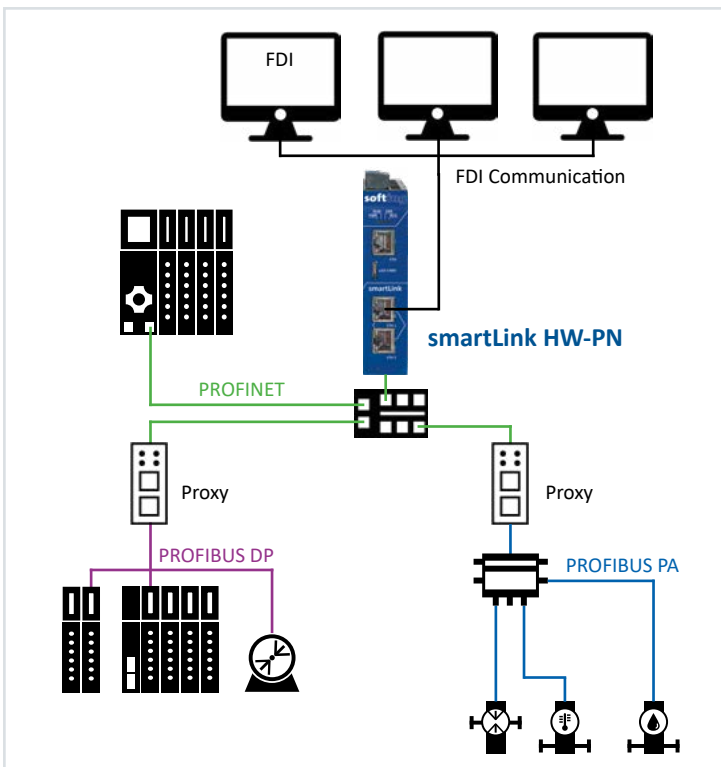

Configuration, Parameterization, Plant Asset Management

- Secure, standardized access to devices
- Parallel to and independent of the controller

Inexpensive and low-risk Integration

- Connection of PROFIBUS devices without additional hardware
- Use of existing infrastructure using the PROFINET/PROFIBUS proxy standard for connecting to the PROFIBUS devices

Compatible with established communication standards

- Implements the standard FDI communication server interface based on OPC UA

smartLink HW-PN

Technical Data

Hardware	Processor	Altera Cyclone V SoC with dual-core ARM Cortex-A9
	Status LEDs (Gateway)	PWR, RUN, ERR, BUS
	Real-Time Clock	Real-Time clock with buffering, setting the time via browser or by NTP server (buffer time depends on conditions such as ambient temperature and duration of use)
Interfaces	Ethernet	1 x IEEE802.3 10BASE-T/100BASE-TX/1000BASE-T, Connector: RJ45
	PROFINET	2 x IEEE802.3 10BASE-T/100BASE-TX, Connector: RJ45; Embedded PROFINET 2-port switch for line or ring topology Protocol: PROFINET RT / IRT, Support of PROFINET redundancy protocols
Supported	Communication Protocols	PROFINET, PROFIBUS FDI communication server (OPC UA)
	PROFINET/PROFIBUS Proxies	Softing: pnGate DP, pnGate PA, pnGate PB aplSwitch Field PA
Physical Properties	Dimensions (H x W x D)	120 mm x 28 mm x 110 mm
	Weight	Approx. 430g
	Power Supply	18 VDC ... 32 VDC; SELV/PELV power supply mandatory Typical input current: 200 mA, maximum input current: 1 A (allowing for in-rush current at switch-on)
	Typical Power Loss	5 W
	Operating Temperature	-40 °C ... +65 °C (see detailed mounting description in user manual)
	Storage Temperature	-40 °C ... +85 °C
	Relative Humidity	10 % ... 95 %, non-condensing
	Cooling	Convection, no fan
	Mounting	DIN rail 35 mm
	Protection Class	IP20
Conformity / Standards	CE	Electromagnetic compatibility (EMC) and Restriction of Hazardous Substances (RoHS) EN 61000-6-2 Generic standards - Immunity standard for industrial environments EN 61000-6-4 Generic standards - Emission standard for industrial environments EN 55032 Electromagnetic compatibility of multimedia equipment - Emission Requirements Class A EN 55011 Industrial, scientific and medical equipment - Radio-frequency disturbance characteristics – Limits and methods of measurement Class A EN 50581:2012/EN IEC 63000:2018 RoHS, Assessment to the restriction of hazardous substances
	FCC	FCC 47 CFR Part 15B Section 15.109 (Class A)
	VCCI	VCCI Voluntary Control Council for Interferences by Information Technology Equipment, April 2015

Scope of Delivery

Hardware	smartLink HW-PN
Documentation	User Guide as PDF download

Order Numbers

GEA-YA-026010	smartLink HW-PN
LRA-AA-027003	smartPlus PN, License access to one field device

Your local Softing contact:

<http://industrial.softing.com>

optimize!
softing