	Type <b>User Guide</b>	Project/Product <b>TCS-10</b>	
	Name <b>TCS-10</b>	Project Code	
Author <b>SB</b>	Department <b>R&amp;D</b>	Date <b>2021-12-08</b>	
Checked	File Name <b>UG - TCS-10 CAN Switch.odt</b>	Printed	
Approved		Revision	Classification <b>INTERNAL</b>
			Page <b>1 (9)</b>
Copyright © TK Engineering Oy. All rights reserved. Reproduction, use or disclosure to third parties without express authority is strictly forbidden.			

## CAN Switch TCS-10 User Guide



The CAN Switch TCS-10 forwards messages between up to four CAN Bus networks, with optional filters and routing tables.

User Guide Version 1.4

### Table of Contents

CAN Switch TCS-10 User Guide.....	1
Definitions, acronyms and abbreviations.....	2
Exclusion of Liability.....	2
Introduction.....	3
Technical Data.....	3
Technical details.....	3
Mechanical Dimensions.....	4
Connectors.....	4
Block schema.....	5
CAN Interface Protection.....	6
Power Supply.....	6

Transceivers.....	6
CAN Terminators.....	6
Isolation.....	6
PE Grounding.....	6
Light Emitting Diodes (LEDs).....	7
Frequently Asked Questions (FAQ).....	7
Legal Information.....	7
RoHS directive.....	7
About This Manual.....	7
Trademarks.....	8
Revision History.....	8
References.....	8

## Definitions, acronyms and abbreviations

ASCII	American standard for information interchange
CAN	Controller Area Network
CAN-ID	Identifier of the CAN-telegram
CANopen	Higher level CAN-protocol by CiA
CiA	CAN in Automation organization
DLC	Data Length Code
EMCY	CANopen emergency protocol or –telegram
HW	Hardware
LSB	Least significant byte
Mbps	Megabits per second
MSB	Most significant byte
NMT	CANopen network management
OD	Object Dictionary
RX	Receive/reception
SDO	CANopen Service Data Object
SW	Software
TX	Transmit/Transmission

## Exclusion of Liability

### **Important note! Please read before using TCS-10**

All machines, vehicles or other technical installations, which are controlled by electronic systems can be through disturbing the network communication or other intervention, lead to disorder or failure, which can injure persons or cause material-damage.

Before you connect TCS-10 to such an electronic system, please ensure that connecting the TCS-10 to your system/network will not injure persons or cause material-damage.

You must not use TCS-10 in applications/environments where the use of TCS-10 can directly lead to disorder or failure, of such machines, vehicles or other technical installations or where such failures or damages can lead to injuring of persons.

Do not use TCS-10 if you are not absolutely certain that you know how to use the TCS-10. If you are uncertain about compatibility between TCS-10 and your system, do not use TCS-10 in your system.

TK Engineering Oy does not take over any liability for damages, injuries etc. caused by the use of TCS-10.

## Introduction

TCS-10 is a product name for a product originally targeted to connect up to 4 CAN buses running different protocols with each other. The TCS-10 takes care of forwarding CAN-messages, CAN-ID, DLC and data contents according to the configuration. The TCS-10 support bit rate configurations on each CAN-port.

Forwarding software enhanced to the network switch function. The TCS-10 has a powerful processor called X-gate used for software forwarding of telegrams to give high performance.

## Technical Data

### Technical details

- Operating voltage 10...40V DC.
- Power consumption max 3.5W typical 3W
- CAN routing ports, CAN1 – CAN4, galvanically isolated 1kV, ISO11898, Max 1Mbps
- CAN configuration port, CANA, ISO11898-2, Max 1Mbps
- Operating temperature range -40°C...+85°C
- Storage temperature range -50°C...+105°C
- Protection class IP30
- Weight ~210g
- Flammability UL94 V0

**Mechanical Dimensions**

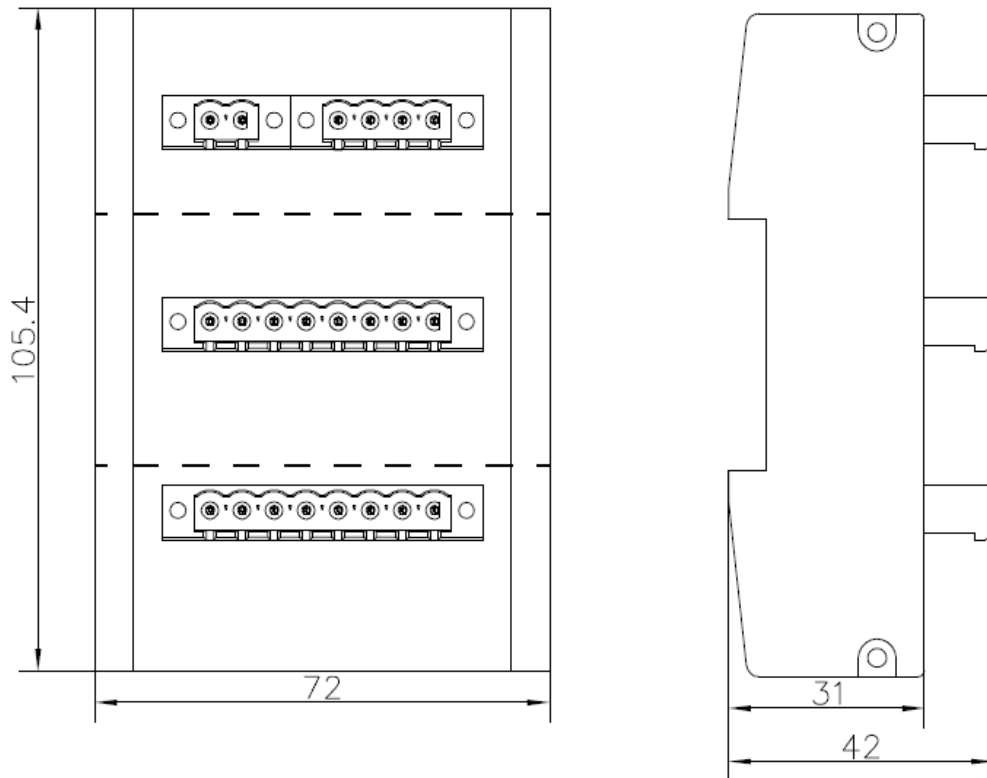

Figure 1: Mechanical dimensions

**Connectors**

The TCS-10 has 2 Phoenix MSTBV 2,5/8-GF-5,08-AU connectors ,1 Phoenix MSTBV 2,5/2-GF-5,08-AU and 1 Phoenix MSTBV 2,5/4-GF-5,08-AU

Phoenix MSTBV 2,5/2-GF-5,08-AU	
X10	
X10.1	POWER +
X10.2	POWER -

Phoenix MSTBV 2,5/4-GF-5,08-AU	
X11	
X11.1	CANA Hi
X11.2	CANA Lo
X11.3	CANA GND
X11.4	CANA Shield

Phoenix MSTBV 2,5/8-GF-5,08-AU	
X12	
X12.1	CAN2 Hi
X12.2	CAN2 Lo
X12.3	CAN2 GND
X12.4	CAN2 Shield
X12.5	CAN4 Hi
X12.6	CAN4 Lo
X12.7	CAN4 GND
X12.8	CAN4 Shield

Phoenix MSTBV 2,5/8-GF-5,08-AU	
X13	
X13.1	CAN1 Hi
X13.2	CAN1 Lo
X13.3	CAN1 GND
X13.4	CAN1 Shield
X13.5	CAN3 Hi
X13.6	CAN3 Lo
X13.7	CAN3 GND
X13.8	CAN3 Shield

Crimp Terminal, Ring, 3mm	
X14	
X14.1	PE

Figure 2: TCS-10 connectors

Block schema

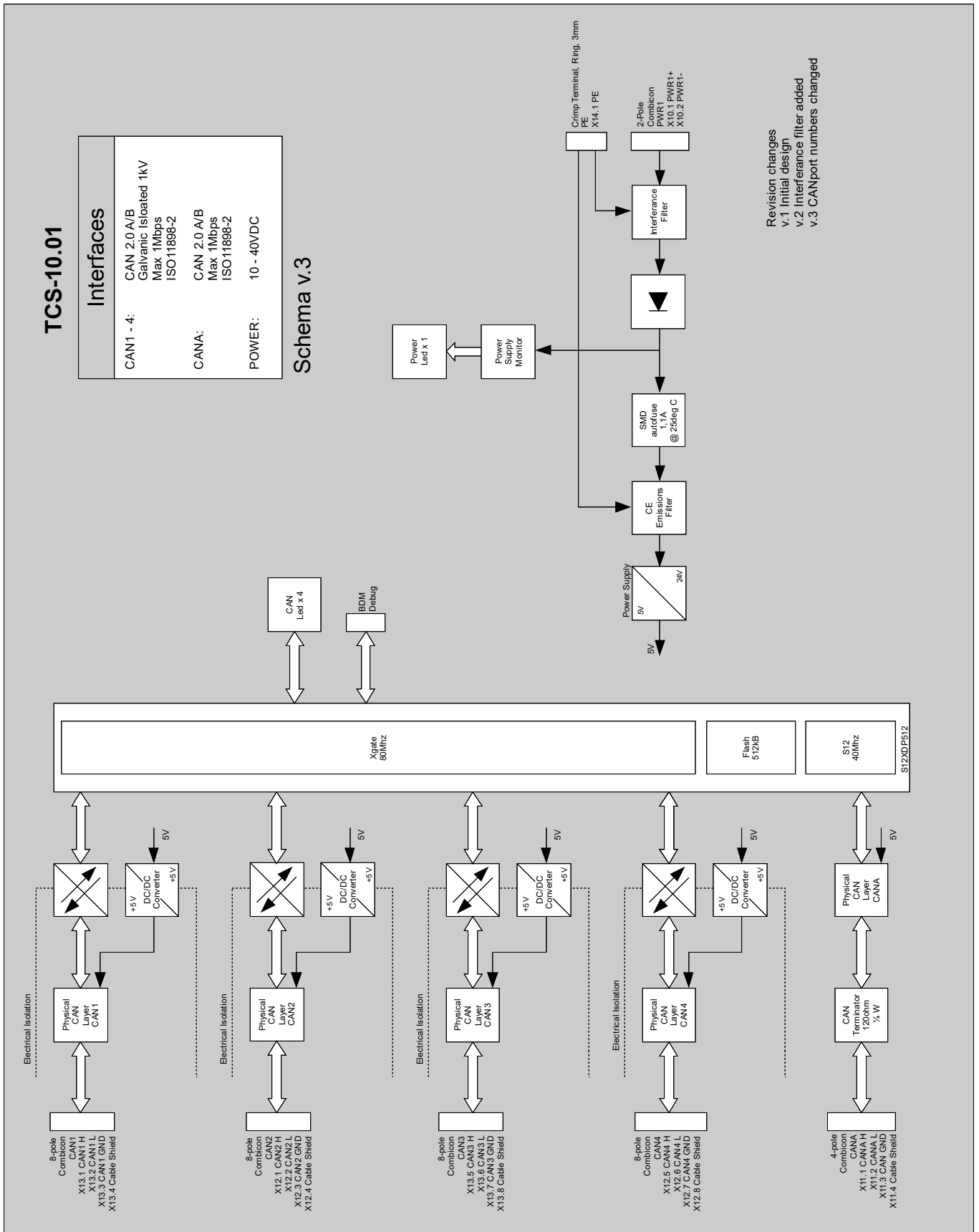

Figure 3: TCS-10.01 block schema

## CAN Interface Protection

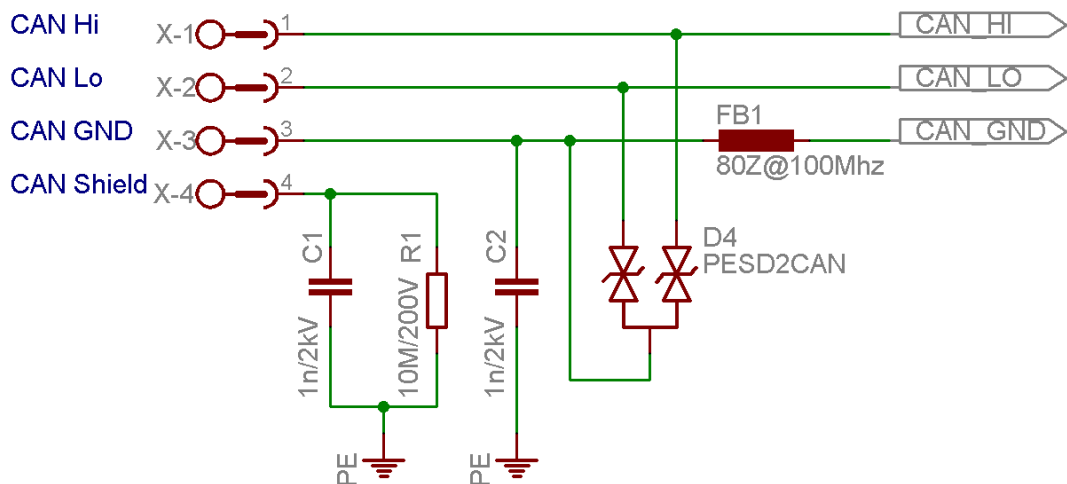

Figure 4: CAN interface protection

The TCS-10 CAN shield is connected to PE through a RC filter. CAN GND is also connected to PE through a EMI capacitor and a ferrite bead. CAN Hi and CAN Lo are protected with a small capacitance dual Bi-directional TVS diode.

## Power Supply

The TCS-10 must be powered by DC voltage from 10 to 40 Volt. The max power consumption when stress tested was 3,5W. In normal operation the power consumption is about 3W.

Table 1: Power supply characteristics

Info	Max	Min	Recommended/Normal
Voltage supply	40VDC	10VDC	12VDC or 24VDC
Power usage	3,5W	2W	3W

## Transceivers

The TCS-10 uses Philips TJA1050 CAN transceivers.

## CAN Terminators

The TCS-10 does not have any terminators internally, all termination need to be added by the end user.

## Isolation

Four of the five CAN ports on the TCS-10 are galvanic isolated. The ports that are isolated are CAN 1, CAN 2, CAN 3 and CAN 4. The CAN A port is not isolated. The data lines are isolated with ADuM 1201. DC/DC isolations are done with C&D NTE0505.

## PE Grounding

The TCS-10 X14 ground strip need to be connected to a high-quality ground point for TCS-10 to fulfill EMC requirements.

## Light Emitting Diodes (LEDs)

The TCS-10 have 6 led's, two green and four yellow. The green ones are for input voltage monitoring. When input voltage drops below 10VDC the power led's switches off.

The yellow CAN led's indicates different CAN controller states.

*Table 2: Power led status*

LED	Status
Off	Input voltage, Low
On	Input voltage, OK

*Table 3: CAN controller led status*

LED	Status
Off	No traffic
On	Traffic
Blink 1/s	TX Error
Blink 5/s	RX Error

*Table 4: Priority of led indication states*

Prio	Status
Prio 1	No traffic
Prio 2	TX Buffer overrun
Prio 3	RX Buffer overrun
Prio 4	Traffic

*Table 5: Led blink times*

State Change	Time
Traffic - Tx Overun – No Traffic	10sec - 10sec
Tx Overun Corrected	2min
Traffic - Rx Overun	10sec
Rx Overun Corrected	2min
No traffic - Traffic	1sec
Traffic – No traffic	10sec

The configuration port does not have any LED indications.

## CAN-Port Usage

The CAN switch consists of 5 CAN ports. Port 1-4 are used for CAN telegram forwarding. Port A is used for TCS-10 configuration. Port CAN A has implemented Micro CANopen for making the configuration via CANopen SDO telegrams.

## Frequently Asked Questions (FAQ)

### **Does the CAN Switch need to be configured before use?**

The default configuration of the CAN Switch is to forward all CAN messages on CAN ports 1-4 using the bitrate 500kbit/s. If this is compatible with your network then no configuration is needed. See the chapter *Factory Settings* for the complete default configuration.

The CAN Switch can be ordered pre-configured for your network. In that case no further configuration is needed.

## Legal Information

### RoHS directive

This product comply with the RoHS (Restriction of Hazardous Substances) directive.

### About This Manual

This document is Copyright © 2009 – 2019 TK Engineering Oy.

This document may not be reproduced without our prior written permission.

We believe that the information in this user guide was accurate at the time of printing. TK Engineering Oy cannot, however, assume responsibility for any errors or omissions in this document. The information in this document is subject to change without notice and should not be taken as a commitment by TK Engineering Oy.

### Trademarks

All product names mentioned in this manual are registered or unregistered trademarks of their respective owners.

## Revision History

The following revision history table summarizes changes contained in this document.

Date	Revision	Author	Description
2009-10-21	1.0	BCAB	New Book
2016-11-25	1.1	BCAB	Added info about CAN termination
2018-01-29	1.2	HL	Updated footer and copyright year info. Grammar and spelling correction.
2019-04-18	1.3	SB	Changed to use current User Guide template. Moved configuration related information to the User Guide for the firmware.
2019-04-23	1.4	TO	Moved all hardware related chapters to this User Guide.

## References

/2/ MC9S12XDP512 Data Sheet, Rev. 2.11, Freescale Semiconductor

/3/ CiA301, CiA Draft Standard Proposal 301, V4.1

/4/ Embedded Networking with CAN and CANopen, Pfeiffer, Ayre and Keydel

/5/ CiA302-1, CiA Addition application layer functions, V3.4.1

/6/ CiA Draft Recommendation 303-3 Indicator specification V1.2



